

illuminate



PROCESS
DESIGN OVERVIEW
MARKETING BRIEF
GANG-UP
MATERIAL SPECIFICATIONS

PPA GROUP 002

DANIEL HUTCHERSON
ISAAC LEVIN
EVAN FUNDERBURK
BROOKS PATRICK
CALVIN HUTTO

CLEMSON UNIVERSITY HARRIS A. SMITH SONOCO INSTITUTE OF PACKAGING DESIGN

PROCESS

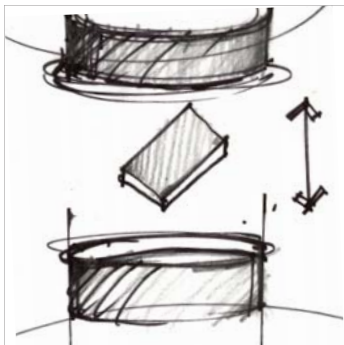

twist and expand!

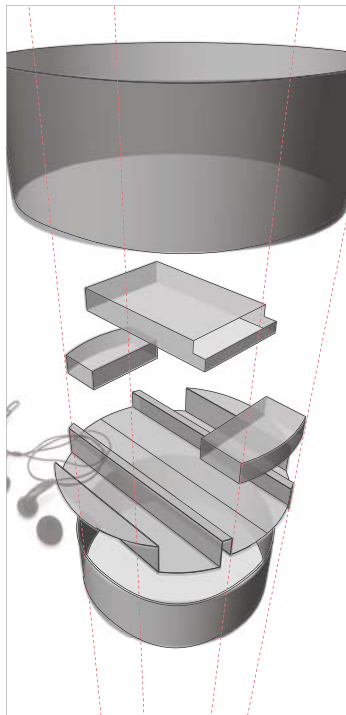

exploded perspective

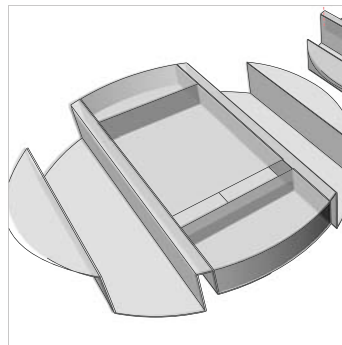

folded tray insert



graphics with implied excitement

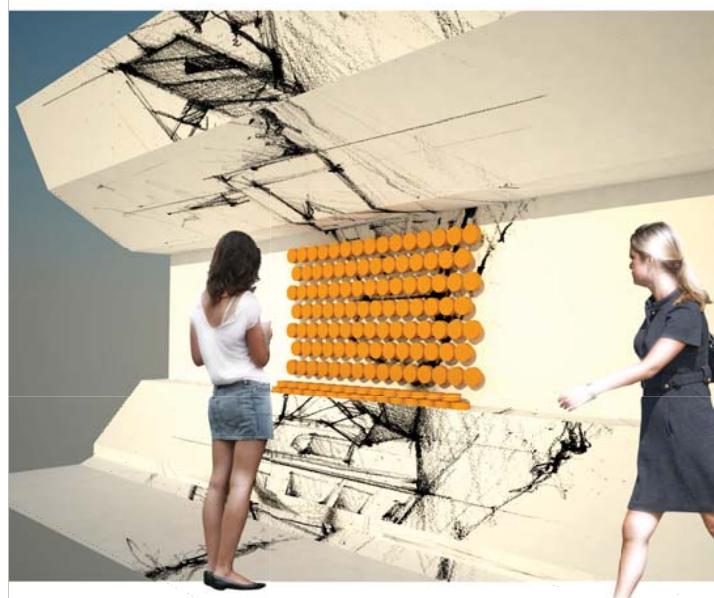

field of points in-store display

PROCESS



printed photovoltaics

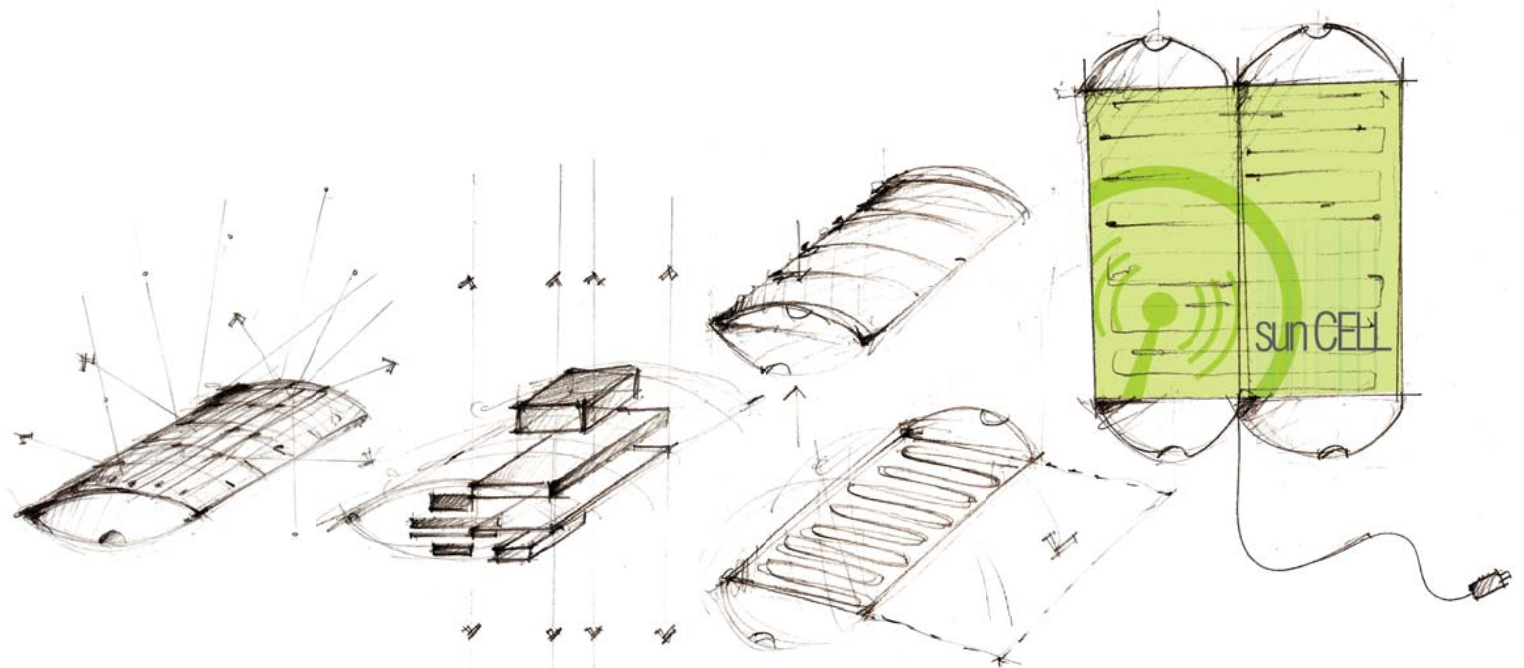

printed solar panel encourages outdoor activities

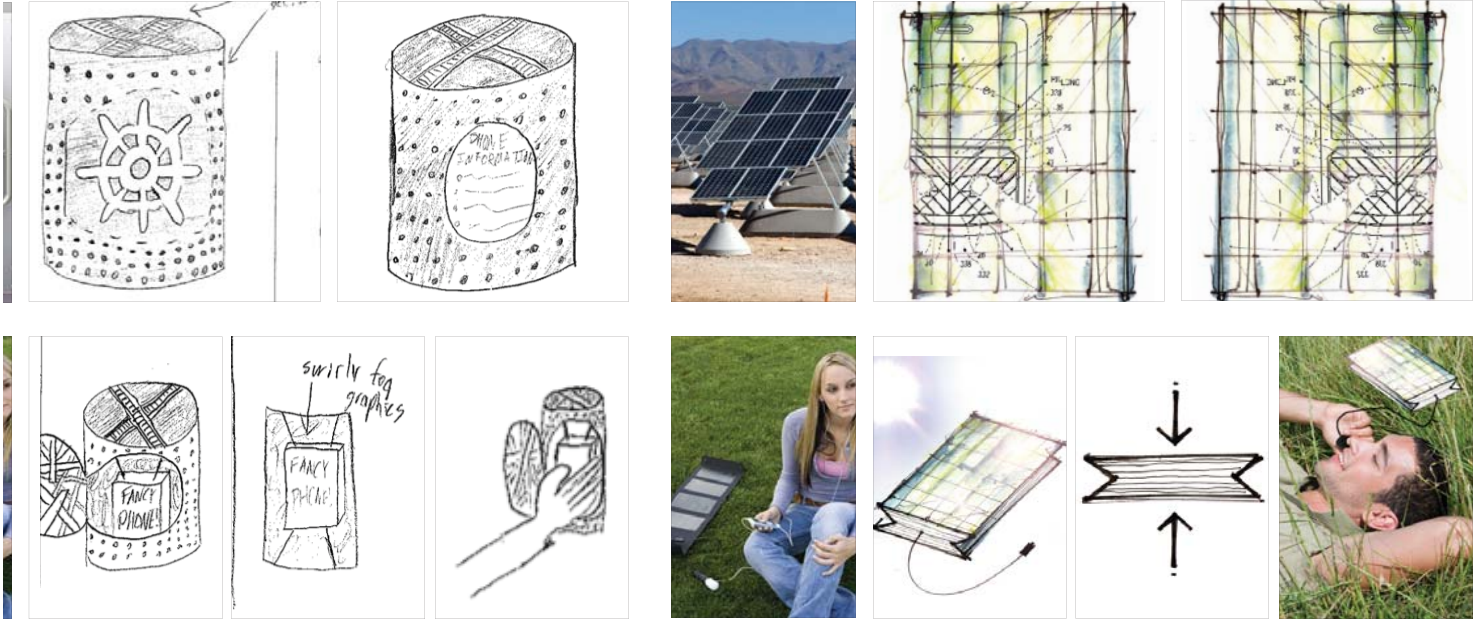

embedded solar panel: a phone with no limits

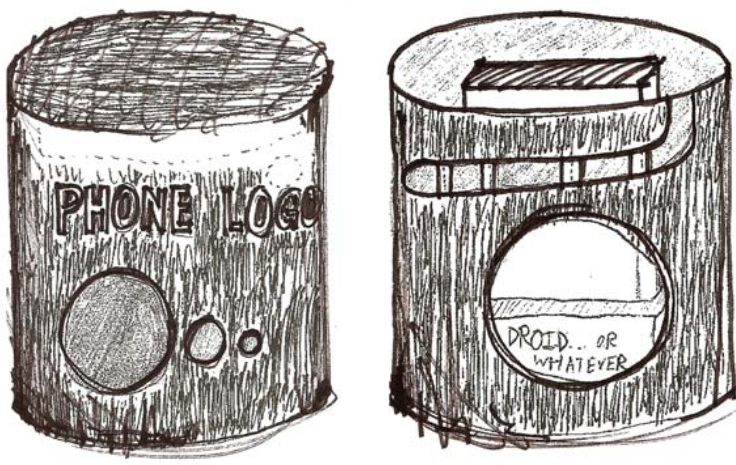

circular design as a protective vault

COMPETITION DESIGN



TOP



BACK

COLOR: fresh and exciting with connections to the sky and ground



DESIGN OVERVIEW



Illuminate is an inspirational design that serves to bridge the gap between sustainability, modern technology, and our natural environment. The primary goal for our product is to provide a package that will not only protect the contents but become its source of energy. Our process relied heavily on reverse engineering to create this useful and functional paperboard package. As the popularity of printed electronics increases and the costs continue to drop, Illuminate will be ground-breaking in providing low cost, highly functional, printed photovoltaic solar panels to the consumer.

Illuminate is minimal waste and maximum exposure to the sun. Printed photovoltaic cells are becoming increasingly more efficient and inexpensive, creating an opportunity for packaging technology. The printed solar panel is conveniently attached to the side of the phone box which can be easily detached via a perforated line. This thin film can either remain on the package or be removed for a convenient plug in energy source when traveling. Charging outdoors in direct sunlight will give you better performance. Alternatively, leave the Illuminate panel attached to a sunny window for future need. The Illuminate panel generates free and clean energy immediately. Replacing your wall and car chargers by capturing solar energy reduces your ecological footprint.

The solar panel and phone rest within a perfect circle. The box is short reflecting the efficient use of paperboard. The diameter and circumference of the box is determined by the projected efficiency of printed photovoltaic cells. The circular shape references the all-encompassing character and universal values referencing the shape of both the sun and the earth. The illuminate package will reference connections to universal travel, all encompassing ideas, and exploration. These ideas will allow the customer to regard the circular shape as a pin hole view of the future with the product.

The graphics of the box are professional and exciting to show the phone's purpose as a high-end product. The top of the box is printed with graphics of suggested solar panels and ways to engage with the phone. Various images are printed on the top of the image of the cell phone to illustrate exciting adventures that are possible with illuminate. The top of the package is also printed with a light, sky blue background that suggests a connection to solar energy. Grass graphics are applied on the insert and bottom of the package to ground the concept. The blue is used in a professional manner and green is used to accent and highlight. Green is also used as a common public connection to color and sustainability the package's main objective.

Creating Illuminate processed energy. Help make this back—and more—by charging from the sun as much as possible. Become a producer of clean energy!

MARKETING PLAN



This cell phone box will be available to retailers selling high-end technology products. This includes but is not limited to stores such as Circuit City, Staples, Fry's and also online stores like Newegg and Buy.com.

The target market is a type of consumer that is excited and interested about the transitions of life and the next new thing in technology. The package appeals to consumers who are excited about sustainable practices while aware of the many environmental issues today regarding our energy crisis. An age bracket does not apply to this product due to the mass appeal already generated by smart phones within all age categories. Increasing the sustainability and function of the package benefits the consumer and supports an increase in demand due to the package and product's unique presence.

A lower end package is designed to conform to the competition's standards. To create this lower-end package, the height of the circular box will decrease, the insert will become more standardized (less creases and folds), and the solar panel will be removed. The printed solar panel for the lower-end package could be purchased separately.

WOW!



Sustainable printed photovoltaics--charge the phone!

Circular design different and eye-catching

Light up design functional package before, after, and during use

One piece tray insert

Small, portable, limitless

Bright and exhilarating color scheme

Allowable space for printed electronics

PRINTED PHOTOVOLTAICS

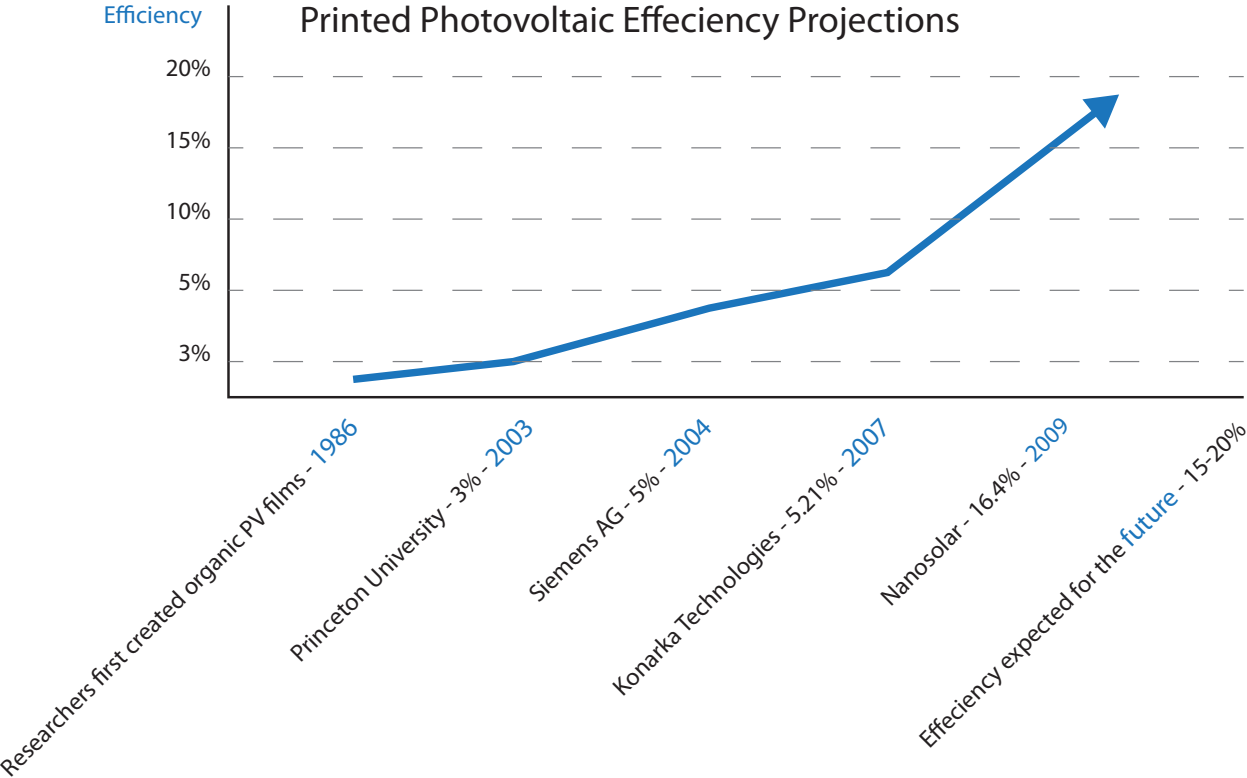

Within the next few years, printed photovoltaic's will become very efficient and more cost effective for users and their environments. This documented increase in efficiency has provided a visual clue for the positively maturing state of the technology.

PRINTED PHOTOVOLTAICS







3 in

Existing High-End Solar Charging Devices

Solar charge time	9 Hours+ (estimated)
Smart Phone Talk Time	4.9 Hrs
Battery Capacity	1650mAh - Li-ion
Power Output	~ 5 Watts
Size of Solar Panel	(3) 3 x 1.3 in
Key Features	Three Folding Panels



illuminate - Printed Photovoltaic

Solar charge time	6.75 Hours+ (projected)
Smart Phone Talk Time	8.5 Hrs (projected)
Battery Capacity	1650mAh - Li-ion
Power Output	~ 5 Watts (projected)
Size of Solar Panel	16 x 1.5 in
Key Features	Printed on Flexible Plastic

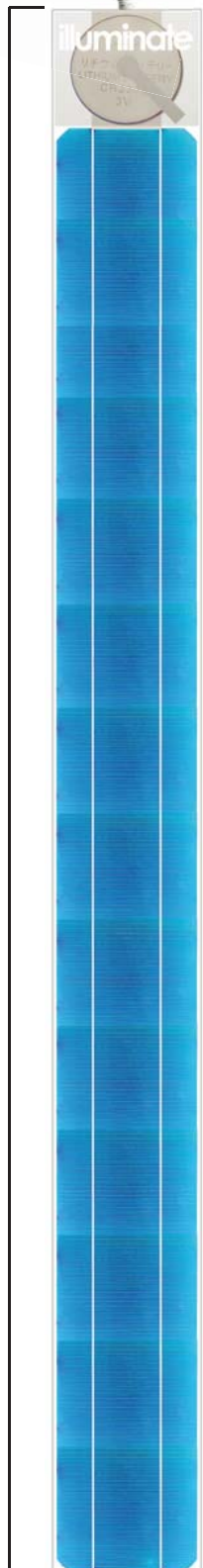

illuminate

16 in

MATERIAL SPECS



18pt GLOSS Paperboard

Roland DG Corporation INK: eco-UV ink 220cc

Printed Photovoltaics: clear plastic film, silver metallic ink, and embedded circular battery

[Our team has proposed the positive effects of applying printed solar panels to paperboard packaging. Due to limited resources and skill level at the University, a functioning solar panel of this type was not possible to fabricate. A full scale mock-up solar panel is provided in the prototype to encourage further development of printed photovoltaics in the future of paperboard packaging. It is our team's hope that technology and sustainability can merge in powerful ways to provide a positive packaging experience.]

DIMENSIONS *high end package*

Dieline Dimensions (in inches)

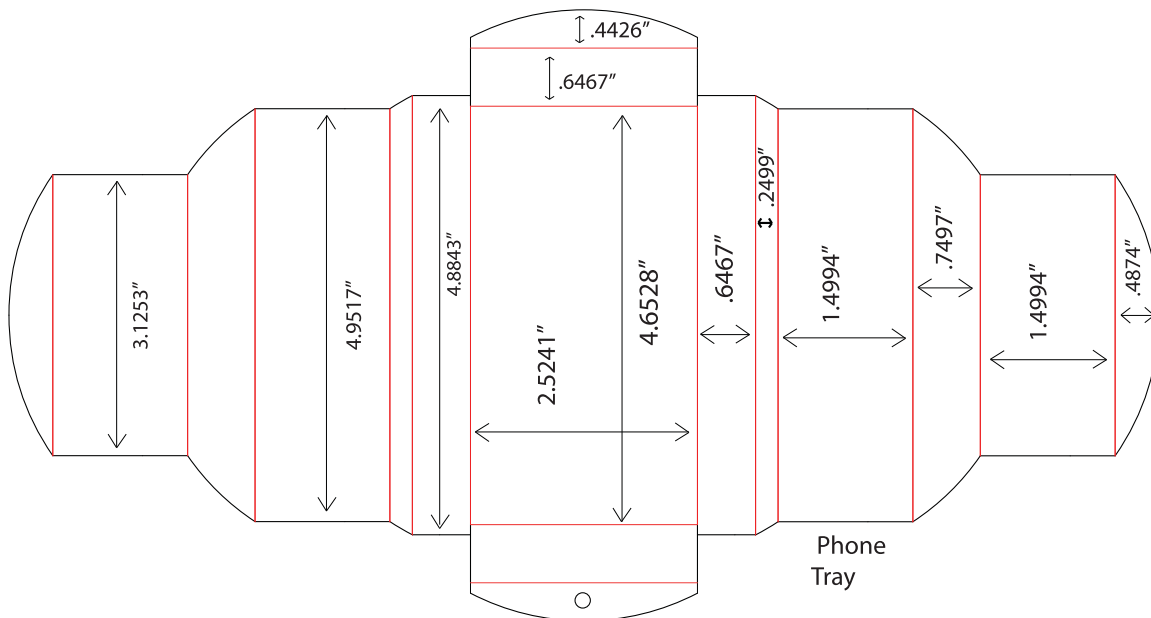
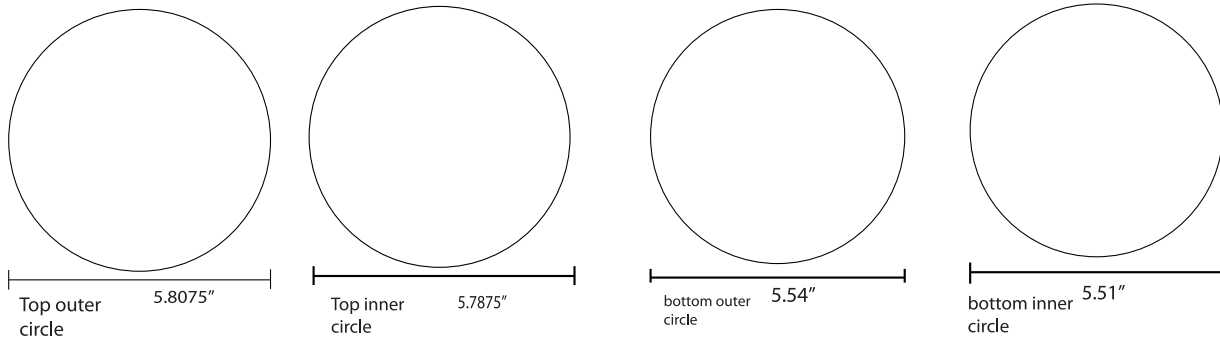
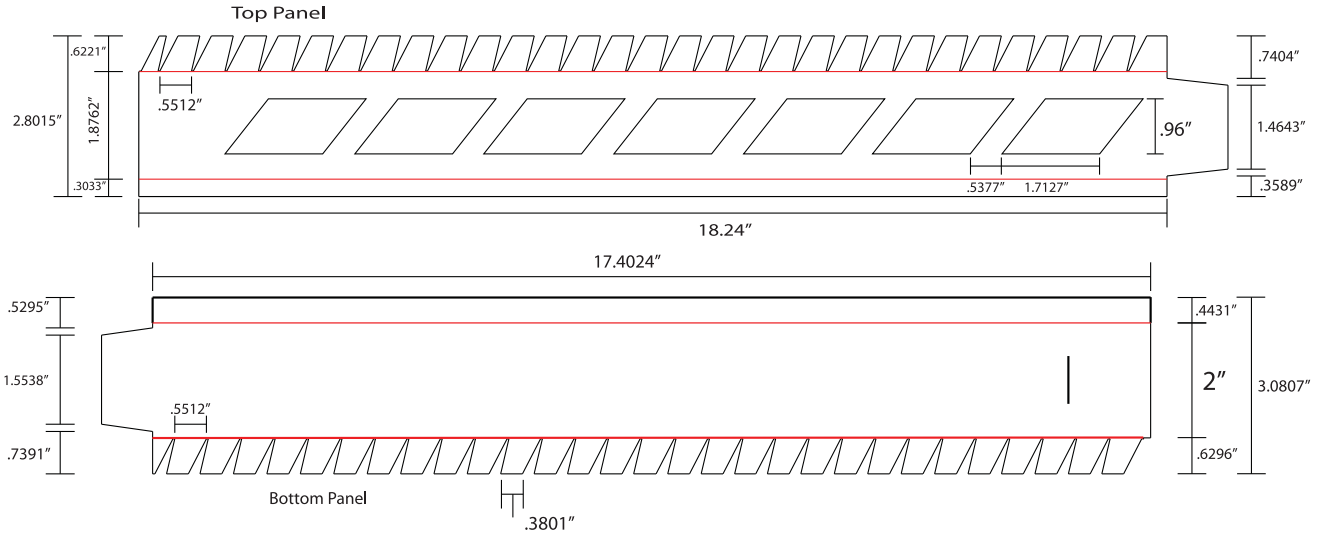

Dieline not to scale*

DIMENSIONS *low end package*

Dieline Dimensions (in inches)

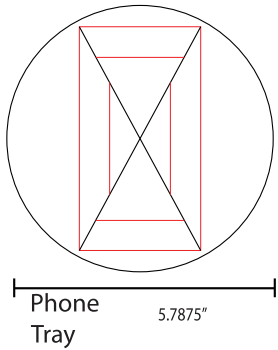
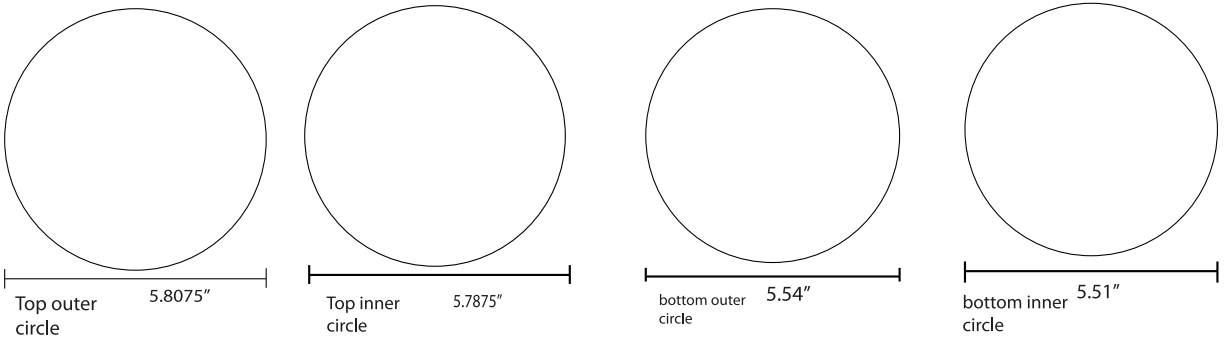
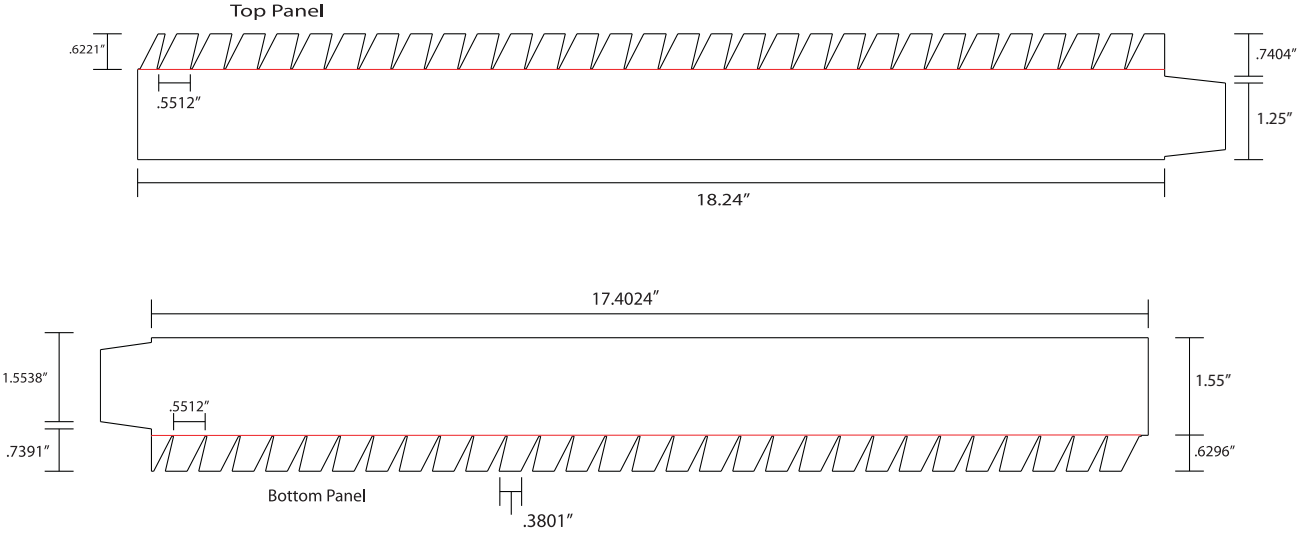

Dieline not to scale*

GANG-UP

